

SCREW: NONE	MATERIAL: COPPER	REV: F	 800-776-9775 www.ilSCO.com
CAT. NO.: SEE CHART	PLATING: EL-TIN	DRAWN BY: DW SCALE: NTS	
INFORMATION SHEET: FORM 157	MARKING: SEE CHART	DATE: 6/3/2008 SIZE: B	
			DWG NO: Y0303-S-4
			SHEET: 1 OF 1

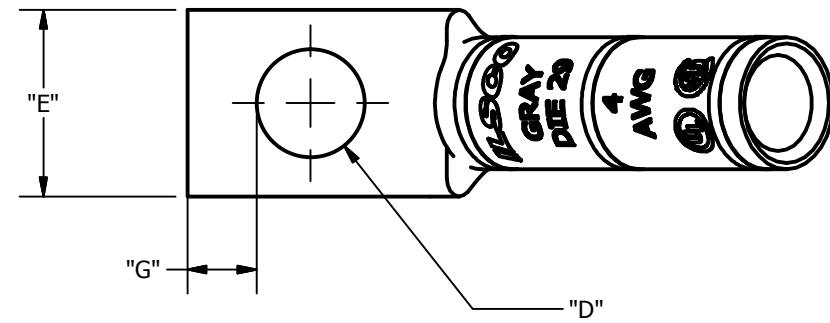

DETAIL C
INK MARK TOP & BOTTOM

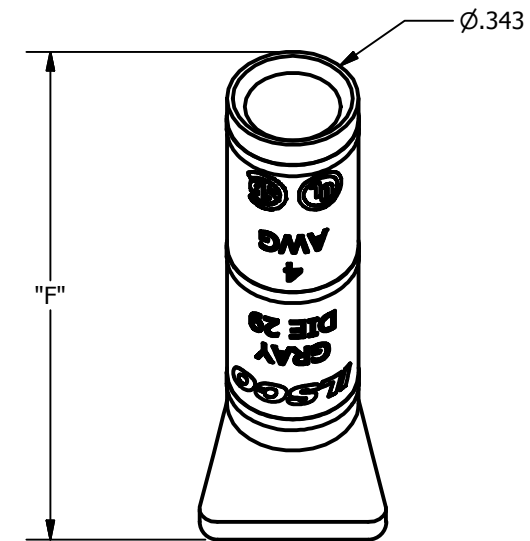
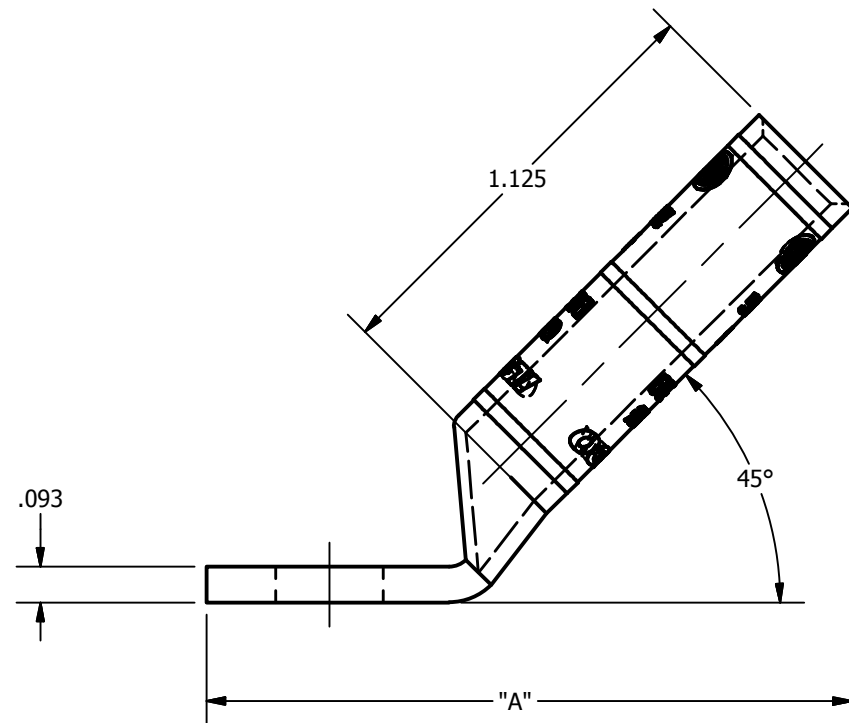

CATALOG NUMBER	"A"	"D"	"E"	"F"	"G"	TANG MARKING
CLNB-4-8-4	1.680	0.195	0.486	1.275	0.129	UL, ILSCO, CSA, CLNB-4-8-4, 8, 4 AWG, DIE 29
CLNB-4-10-4	1.680	0.219	0.486	1.275	0.148	UL, ILSCO, CSA, CLNB-4-10-4, 10, 4 AWG, DIE 29
CLNB-4-14-4	1.798	0.281	0.486	1.280	0.180	ILSCO, C-4-14, UL, CSA, 4 AWG,
CLNB-4-12-4	2.368	0.562	0.750	1.280	0.265	UL, ILSCO, CSA, CLNB-4-12-4, 1/2, 4 AWG, DIE 29
CLNB-4-38-4	1.993	0.406	0.593	1.280	0.211	UL, ILSCO, CSA, CLNB-4-38-4, 3/8, 4 AWG, DIE 29
CLNB-4-516-4	1.993	0.343	0.486	1.280	0.180	UL, ILSCO, CSA, CLNB-4-516-4, 5/16, 4 AWG, DIE 29